

# ZL8101\_30AEV2Z 30A Demo Board

## Description

The ZL8101 is an integrated mixed-signal power conversion and management IC that combines an efficient step-down DC/DC converter with key power and thermal management functions in a single package. The ZL8101 incorporates current sharing and adaptive efficiency-optimization algorithms to provide a flexible, efficient power IC building block.

The ZL8101\_30AEV2Z Demo Board is a 6-layer board demonstrating a 30A synchronous buck converter. Sequencing, tracking, margining, plus other features can be evaluated using this board.

A USB to SMBus adapter board can be used to connect the demo board to a PC. The PMBus command set is accessed by using the Zilker Labs PowerNavigator™ evaluation software from a PC running Microsoft Windows.

## Ordering Information

PART NUMBER	DESCRIPTION
ZL8101_30AEV2Z	30A Single Phase Demo Board

## Key Features

- 30A Synchronous Buck Converter
- Optimized for High Current and High Efficiency
- Configurable through SMBus
- Onboard Enable Switch
- Power-Good Indicator

## Target Specifications

- $V_{IN} = 12V$
- $V_{OUT} = 1V/30A$
- $F_{SW} = 533kHz$
- Efficiency: >88% at 20A
- Output Ripple:  $\pm 1\%$
- Dynamic Response:  $\pm 3\%$  (33%-83%-33% LOAD STEP,  $di/dt = 5A/\mu s$ )
- Operating Temperature:  $+25^\circ C$

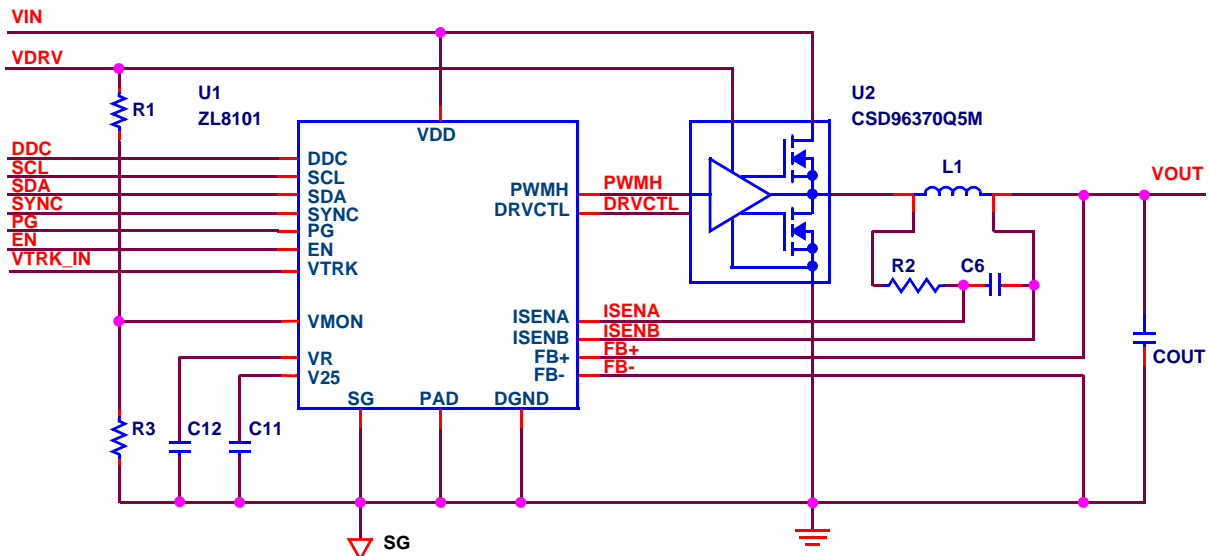

FIGURE 1. ZL8101\_30AEV2Z 30A DEMO BOARD SIMPLIFIED SCHEMATIC

## Functional Description

The ZL8101\_30AEV2Z 30A Demo Board provides all circuitry required to demonstrate the features of the ZL8101. The ZL8101 30A has a functionally optimized ZL8101 circuit layout that allows efficient operation up to the maximum output current. Power and load connections are provided through plug-in sockets.

A majority of the features of the ZL8101 such as soft-start delay and ramp times, supply sequencing, voltage tracking, and voltage margining are available on this board. For voltage tracking and sequencing evaluation, the board can be connected to any other Zilker Labs evaluation boards that supports the Digital DC (DDC) bus.

Figure 1 shows a simplified schematic of the ZL8101\_30AEV2Z 30A Demo Board. All power to the board (VIN and I<sup>2</sup>C bus) must be removed before changing the jumpers.

The hardware enable function is controlled by a toggle switch on the ZL8101\_30AEV2Z 30A board. The power-good (PG) LED indicates the state of PG when external power is applied to the ZL8101\_30AEV2Z 30A board. The right angle headers at opposite ends of the board are for connecting a USB to SMBus adapter board or for easy chaining of multiple evaluation boards.

Figure 2 shows the ZL8101\_30AEV2Z 30A Demo Board complete circuit. The circuit consists of the ZL8101 IC with its minimal component count to realize a 30A buck converter. The board layout has been optimized for thermal performance. Figure 3 is the board interface circuitry. Figures 5 through 10 show the PCB layout for the board, including the board fabrication notes.

The bill of materials (BOM) and configuration file are also included for reference.

## Operation

### PMBus Operation

The ZL8101 utilizes the PMBus protocol. The PMBus functionality can be controlled via USB from a PC running the PowerNavigator evaluation software in a Windows XP, Windows 2000/NT, or Windows 7 operating system.

Install the evaluation software using the CD included in the ZL8101\_30AEV2Z 30A Demo Board kit.

For board operation, connect the included USB-to-SMBus adapter board to J2 of the ZL8101\_30AEV2Z 30A Demo board. Connect the desired load and an appropriate power supply to the input and connect the included USB cable to the PC running the PowerNavigator evaluation software. Place the ENABLE switch in "DISABLE" and turn on the power.

The evaluation software allows modification of all ZL8101 PMBus parameters. The ZL8101 device on the board has been pre-configured as described in the Target Specifications on the front page, but the user may modify the operating parameters through the PowerNavigator software or by loading a predefined scenario from a configuration file.

Use the mouse-over pop-ups for PowerNavigator help. Refer to Zilker Labs application note [AN2033](#) for PMBus details.

The ENABLE switch can then be moved to "ENABLE" and the ZL8101\_30AEV2Z 30A Demo board can be tested. Alternately, the PMBus ON-OFF CONFIG and OPERATION commands may be used.

## Quick Start Guide

### Stand Alone Operation

1. Set ENABLE switch to "DISABLE".
2. Apply load to VOUT+/VOUT- .
3. Connect the USB to SMBus adapter board to J2 of the board.
4. Ensure that jumper shorting headers J1, J6, and J7 are installed.
5. Connect supplied USB cable from computer to USB to SMBus adapter board.
6. Connect power supply to VIN+/VIN- (supply turned off).
7. Turn power supply on.
8. Set ENABLE switch to "ENABLE".
9. Monitor the ZL8101\_30AEV2Z 30A demo board operation using an oscilloscope.

### USB (PMBus) Operation

1. Set ENABLE switch to "DISABLE".
2. Apply load to VOUT+/VOUT- .
3. Connect power supply to VIN+/VIN- (supply turned off).
4. Turn power supply on.
5. Insert the Zilker Labs Eval Kit CD.
6. Connect USB to SMBus adapter board to J2 of ZL8101\_30AEV2Z 30A Demo Board.
7. Connect supplied USB cable from computer to USB to SMBus adapter board.
8. Upon first-time connection, the Found New Hardware Wizard will appear.
9. Select 'No' at prompt to search the Internet for drivers.
10. Follow the steps on the screen to install the drivers from the CD.
11. Install the PowerNavigator evaluation software by running setup.exe from the PowerNavigator\_installer folder on the CD.
12. Using PowerNavigator, set the enable mode to PMBus Enable, press the PMBus Enable button on the PowerNavigator opening screen.
13. Monitor and configure the ZL8101\_30AEV2Z 30A Demo Board using PMBus commands in the evaluation software.
14. Test the ZL8101\_30AEV2Z 30A Demo Board operation using an oscilloscope and the evaluation software.

Typical room temp efficiency curves are shown in Figure 11. Typical transient and operational waveforms are shown in Figures 12 through 15.

# Board Schematics

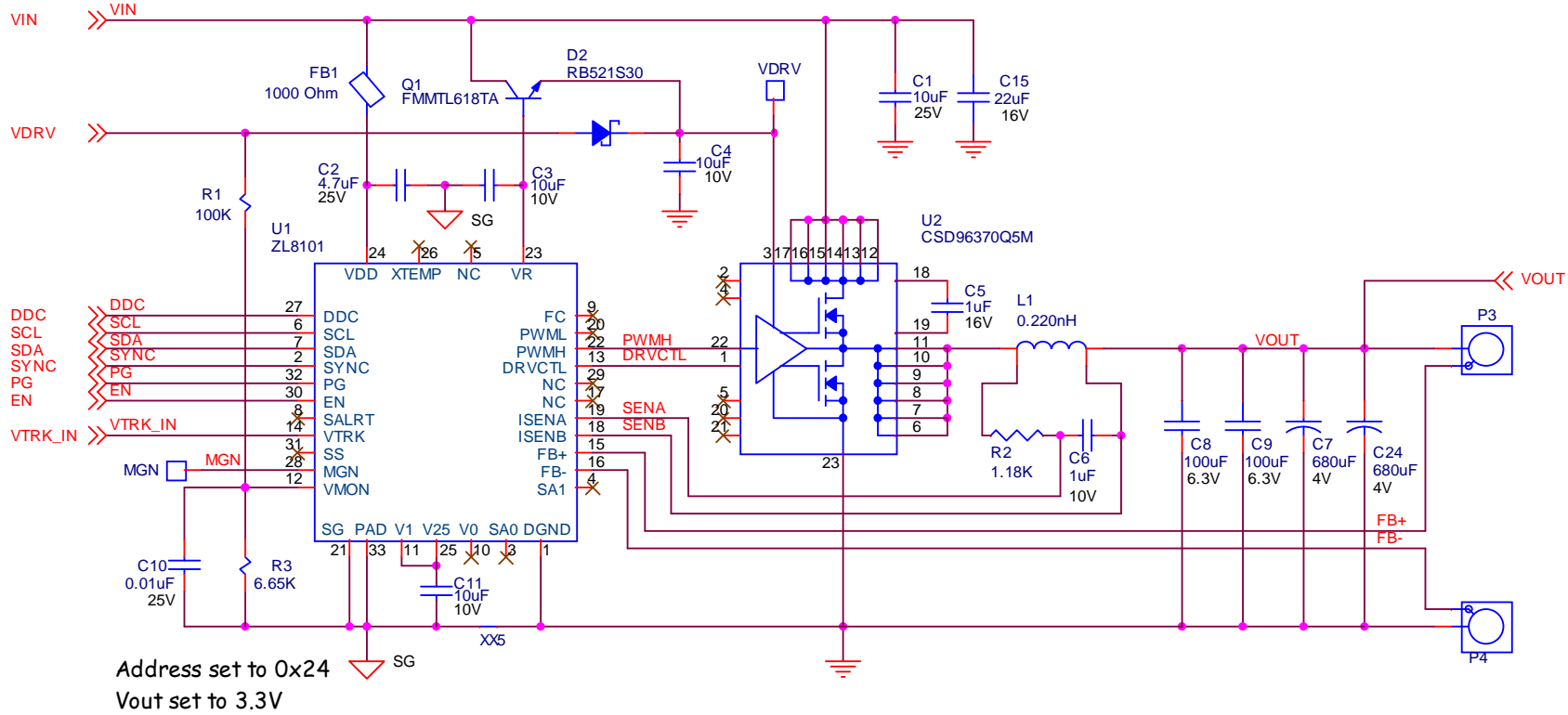

FIGURE 2. ZL8101\_30AEV2Z 30A DEMO BOARD COMPLETE CIRCUIT

# Board Schematics (Continued)

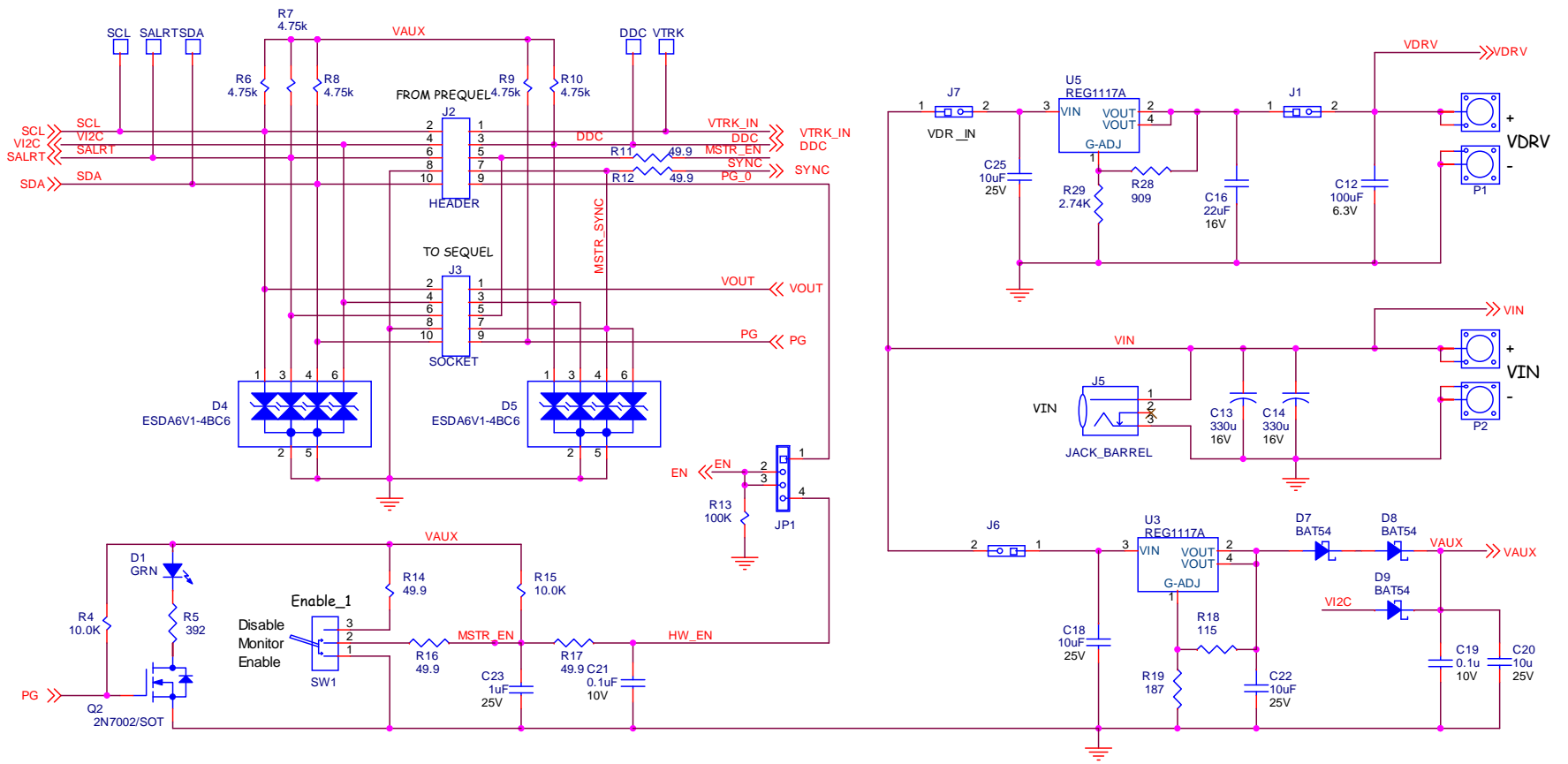

FIGURE 3. ZL8101\_30AEV2Z 30A DEMO BOARD – INTERFACE CIRCUITRY

# Application Note 1781

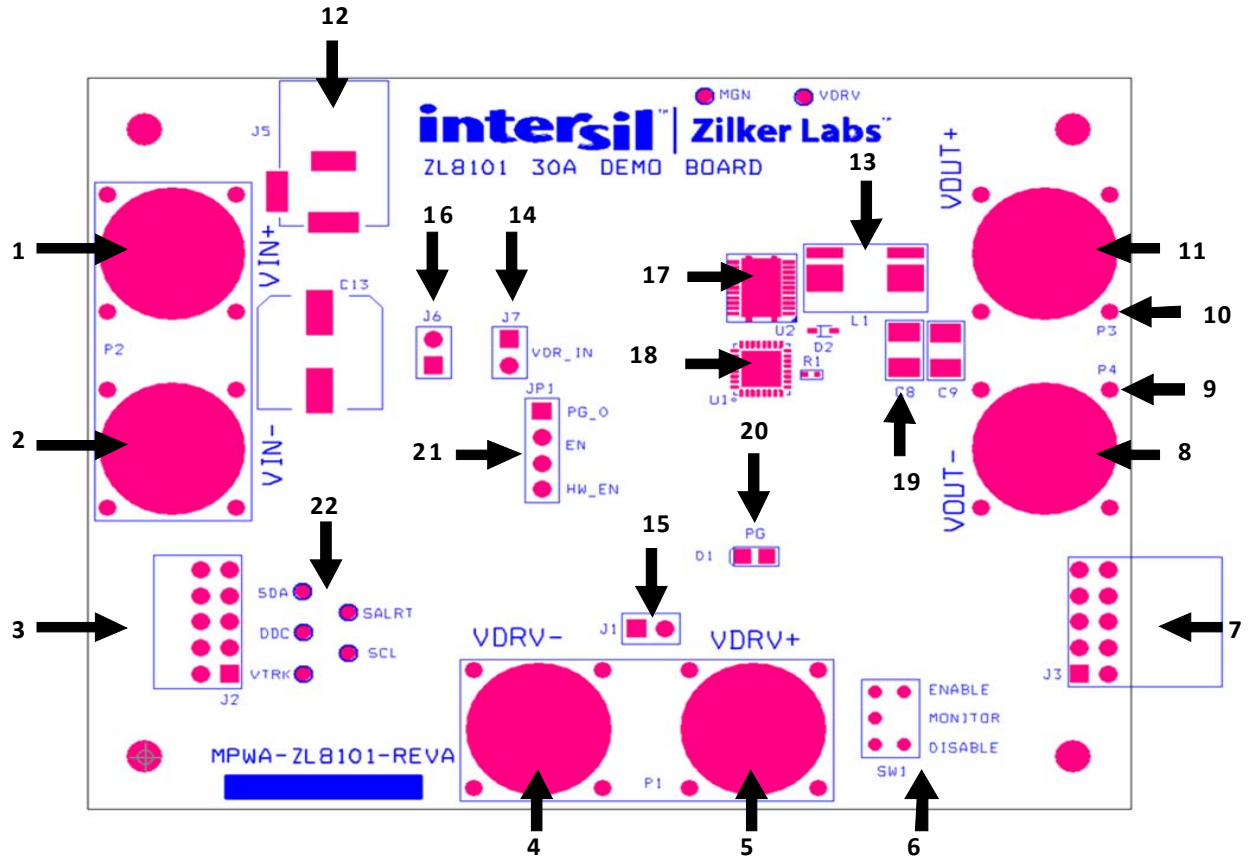

FIGURE 4. ZL8101\_30AEV2Z 30A DEMO BOARD GUIDE

The top view of the ZL8101\_30AEV2Z 30A Demo Board is shown in Figure 4, and the most important parts of the board are covered in Table 1

# Application Note 1781

**TABLE 1. COMMENTS ABOUT DIFFERENT PARTS IN THE ZL8101\_30AEV2Z 30A DEMO BOARD**

ITEM	QUANTITY	REFERENCE	VALUE	TOLERANCE	RATING	TYPE	MANUFACTURER	PART NUMBER	DISTRIBUTOR	DIST. PN
1	1	C1	10µF	±10%	25V	X7R	Taiyo Yuden	TMK316B7106KL-TD	Digikey	587-2399-2-ND
2	1	C2	4.7µF	±10%	25V	X7R	AVX	0805YC475KAT2A	Digikey	478-5722-1-ND
3	3	C3, C4, C11	10µF	±10%	10V	X7R	Murata	GRM21BR71A106KE51L	Digikey	490-3905-2-ND
4	1	C5	1µF	±10%	16V	X7R	Kemet	C0603C105K4RACTU	Digikey	C0603C105K4RACTU-ND
5	1	C6	1µF	10%	10V	X7R	Taiyo Yuden	LMK107B7105KA-T	Digikey	587-1242-2-ND
6	2	C7, C24	680µF	20%	4V	AL POLY	Kemet	T530Y687M004ATE005	Digikey	399-4750-1-ND
7	3	C8, C9, C12	100µF		6.3V	X5R	Taiyo Yuden	JMK325BJ107MY-T	Digikey	587-1388-2-ND
8	1	C10	0.01µF	±10%	25V	X7R	Kemet	C0402C103K3RACTU	Digikey	399-1278-2-ND
9	2	C13, C14	330µ	20%	16V	AL POLY	United Chemi-Con	APXA160ARA331MJC0G	Digikey	565-3081-2-ND
10	2	C15, C16	22µF	20%	16V	X5R	Murata	GRM31CR61C226ME15L	Digikey	490-4739-2-ND
11	3	C18, C22, C25	10µF	10%	25V	X5R	Panasonic - ECG	ECJ-3YB1E106K	Digikey	PCC2414TR-ND
12	1	C19	0.1µ	10%	10V	X7R	Kemet	C0603C104K8RACTU	Digikey	399-1095-2-ND
13	1	C20	10µ	10%	25V	X5R	Panasonic - ECG	ECJ-3YB1E106K	Digikey	PCC2414TR-ND
14	1	C21	0.1µF	10%	10V	X7R	Kemet	C0603C104K8RACTU	Digikey	399-1095-2-ND
15	1	C23	1µF	10%	25V	X5R	Taiyo Yuden	TMK107BJ105KA-T	Digikey	587-1248-2-ND
16	1	D1	GRN		2V		Chicago Minature	CMD17-21VGC	Mouser	606-CMD17-21VGC
17	1	D2	RB521S30		30V	Schottky	ON SEMI	RB521S30	Digikey	RB521S30CT-ND
18	2	D4, D5	ESDA6V1-4BC6		6.1V, 80W		ST Micro	ESDA6V1-4BC6	Digikey	497-4643-2-ND
19	3	D7, D8, D9	BAT54		30V	Schottky	On Semi	BAT54XV2T10S	Digikey	BAT54XV2T10STR-ND
20	1	FB1	1000 Ω		150mA	Ferrite	Taiyo Yuden	BK1005HM102-T	Digikey	587-1835-2-ND
21	1	JP1	4 PIN				Tyco	3-644456-4	Digikey	A31114-ND
22	3	J1, J6, J7	2 POS			VERT	Samtec	TSW-102-07-L-S	Digikey	SAM1031-02-ND
23	1	J2	HEADER			RA	Samtec	TSW-105-08-T-D-RA	Digikey	SAM1049-05-ND
24	1	J3	SOCKET			RA	Samtec	SSQ-105-02-T-D-RA	Digikey	SAM1224-05-ND
25	1	J5	JACK_BARREL		1.5A @ 18VDC	RA	Kobiconn	163-5004-E	Mouser	163-5004-E
26	1	L1	0.220nH		70	Inductor	ITG	SL3732_R22KHF	ITG	SL3732_R22KHF
27	2	P1, P2	JACK_DUAL_BANANA		15A		Emerson	108-0740-001	Digikey	J147-ND
28	2	P3, P4	JACK_BANANA_1						Digikey	J147-ND
29	1	Q1	FMMTL618TA		20V	NPN	Diodes Inc	FMMTL618TA	Digikey	FMMTL618CT-ND
30	1	Q2	2N7002/SOT		60V 115mA	N-CH	ON SEMI	2N7002LT1	Digikey	2N7002LT10STR-ND
31	1	R1	100k	1%		1/16W	Vishay/Dale	CRCW0402100KFKED	Digikey	541-100KLTR-ND
32	1	R2	1.18k	1%		Resistor	Panasonic - ECG	ERJ-3EKF1181V	Digikey	P1.18KHTR-ND
33	1	R3	6.65k	1%		1/16W	Panasonic - ECG	ERJ-2RKF6651X	Digikey	P6.65KLTR-ND
34	1	R4	10.0k	1%		1/16W	Yageo	RC0402FR-0710KL	Digikey	311-10.0KLTR-ND
35	1	R5	392	1%		THK FILM	Panasonic - ECG	ERJ-3EKF3920V	Digikey	P392HTR-ND
36	5	R6, R7, R8, R9, R10	4.75k	1%		1/16W	Panasonic - ECG	ERJ-2RKF4751X	Digikey	P4.75KLTR-ND
37	4	R11, R12, R16, R17	49.9	1%	100mW	THK FILM	Panasonic - ECG	ERJ-3EKF49R9V	Digikey	P49.9HTR-ND
38	1	R13	100k	1%	63mW	THK FILM	Panasonic - ECG	ERJ-2RKF1003X	Digikey	P100KLTR-ND
39	1	R14	49.9	1%	63mW	THK FILM	Vishay/Dale	CRCW040249R9FKED	Digikey	541-49.9LTR-ND
40	1	R15	10.0k	1%	63mW	THK FILM	Panasonic - ECG	ERJ-2RKF1002X	Digikey	P10.0KLTR-ND
41	1	R18	115	1%	100mW	THK FILM	Panasonic - ECG	ERJ-3EKF1150V	Digikey	P115HTR-ND

# Application Note 1781

**TABLE 1. COMMENTS ABOUT DIFFERENT PARTS IN THE ZL8101\_30AEV2Z 30A DEMO BOARD (Continued)**

ITEM	QUANTITY	REFERENCE	VALUE	TOLERANCE	RATING	TYPE	MANUFACTURER	PART NUMBER	DISTRIBUTOR	DIST. PN
42	1	R19	187	1%	100mW	THK FILM	Panasonic - ECG	ERJ-3EKF1870V	Digikey	P187HTR-ND
43	1	R28	909	1%	100mW	THK FILM	Panasonic - ECG	ERJ-3EKF9090V	Digikey	P909HTR-ND
44	1	R29	2.74k	1%	100mW	THK FILM	Panasonic - ECG	ERJ-3EKF2741V	Digikey	P3.32KHTR-ND
45	1	SW1	SW_SPDT			PCB VERT	NKK	G13AP-RO	Mouser	633-G13AP-RO
53	1	U1	ZL8101				Intersil	ZL8101	Intersil	ZL8101
54	1	U2	CSD96370Q5M		25V		Texas Instruments	CSD96370Q5M	Digikey	296-28235-2-ND
55	2	U3, U5	REG1117A				Texas Instruments	REG1117A	Digikey	REG1117A-ND

## Board Layout – 6 Layers

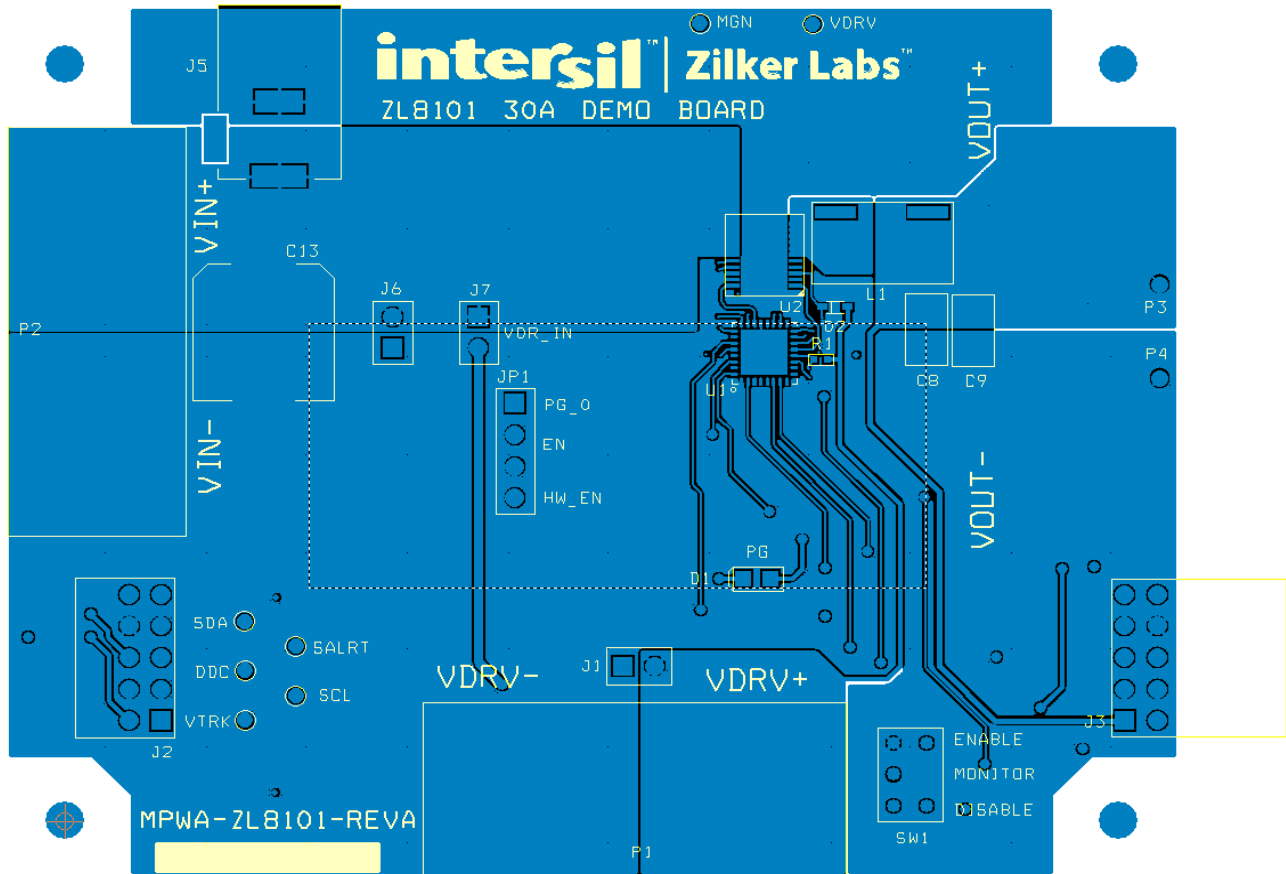

FIGURE 5. PCB - TOP LAYER



Board Layout – 6 Layers (Continued)

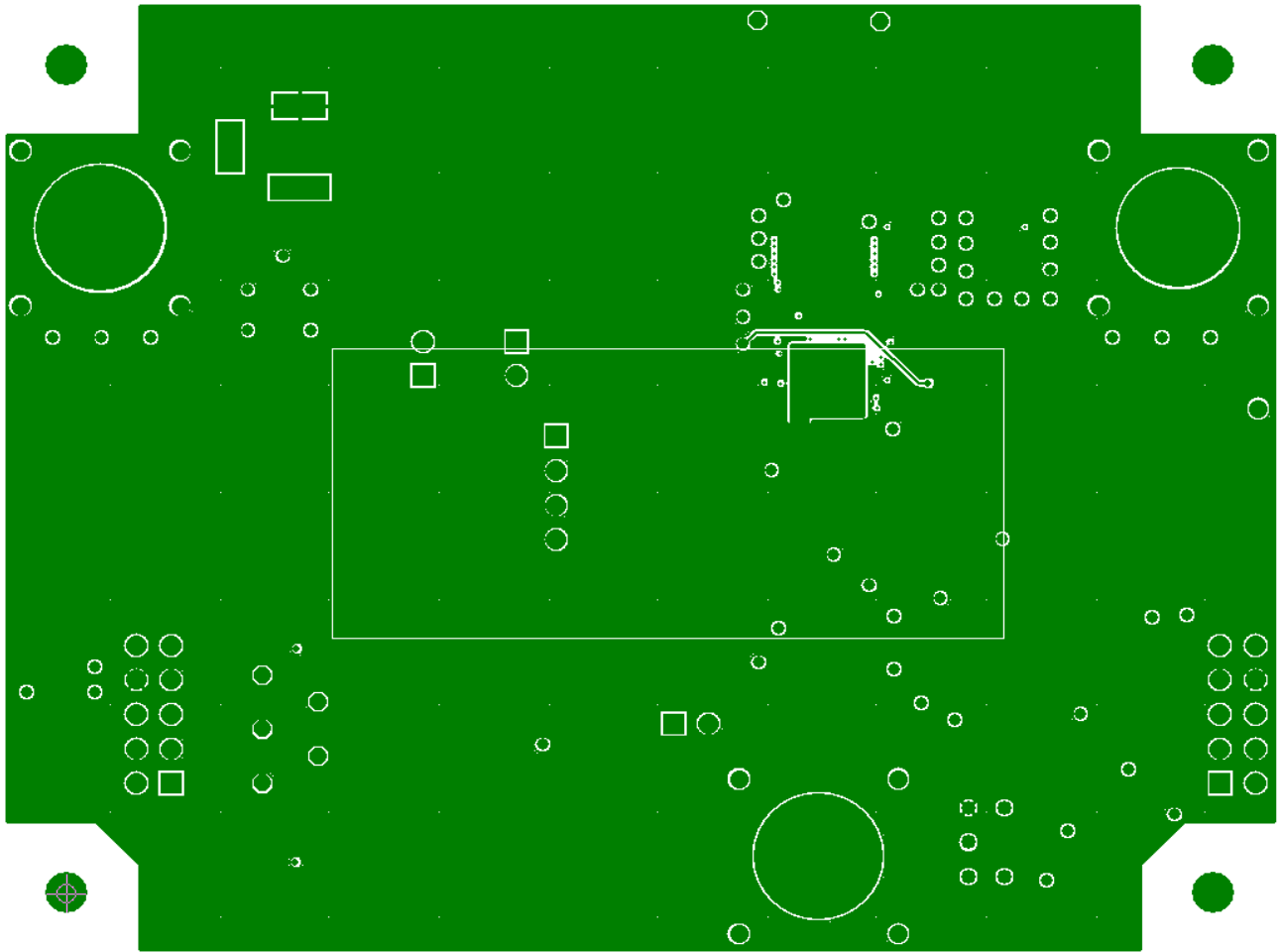

FIGURE 6. PCB - INNER LAYER 1 (VIEWED FROM TOP)

## Board Layout – 6 Layers (Continued)

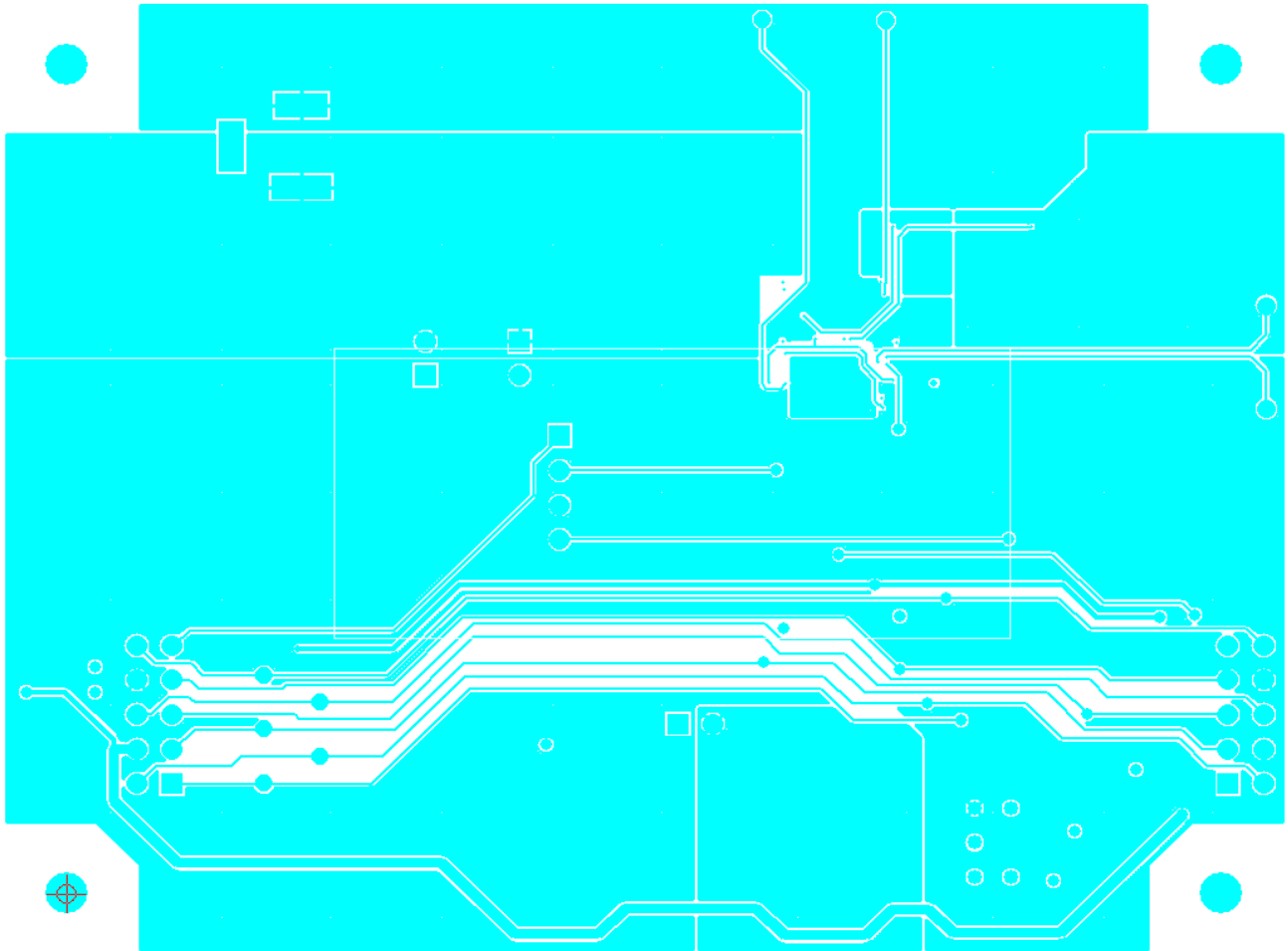

FIGURE 7. PCB - INNER LAYER 2 (VIEWED FROM TOP)

## Board Layout – 6 Layers (Continued)

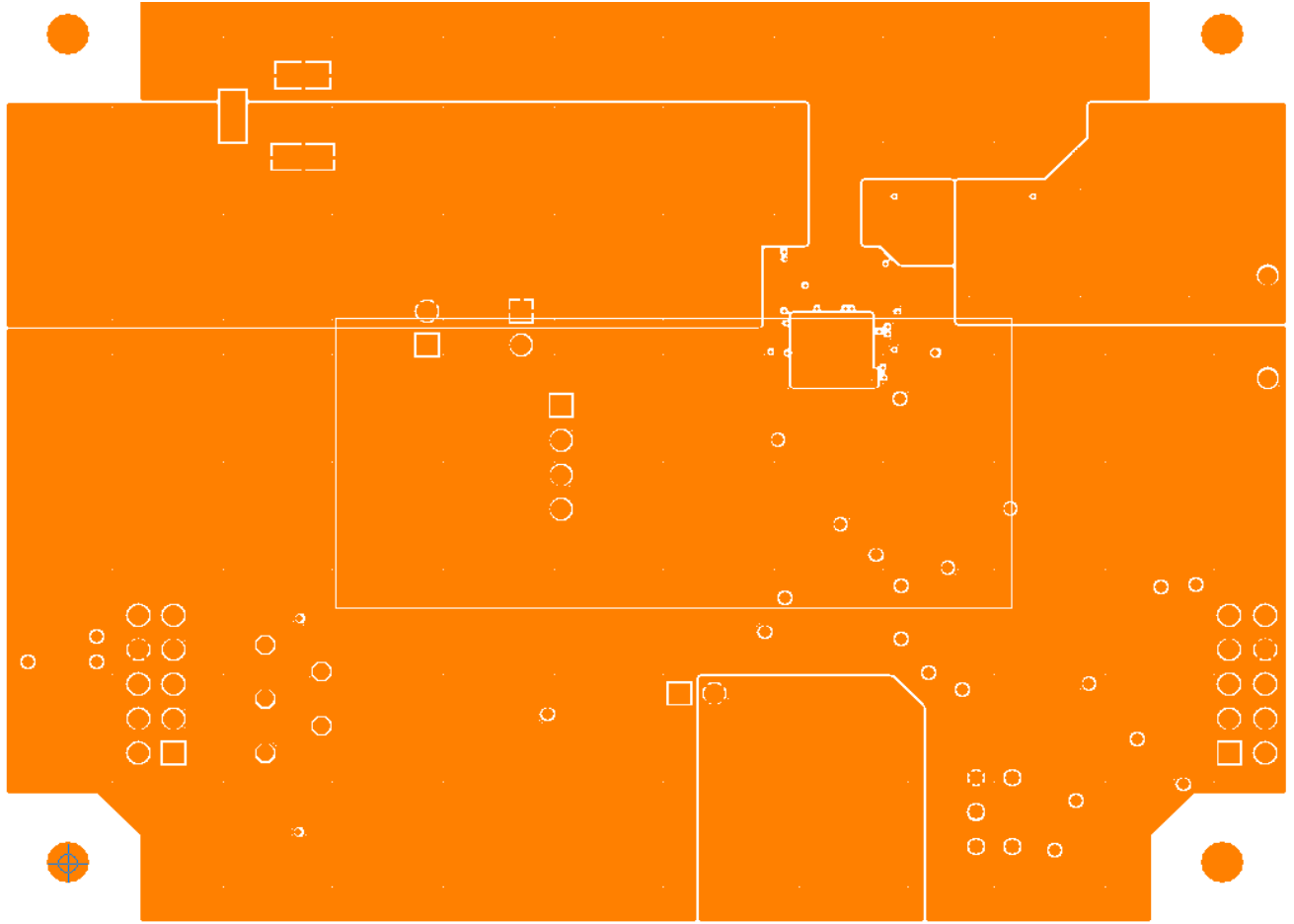

FIGURE 8. PCB - INNER LAYER 3 (VIEWED FROM TOP)

## Board Layout – 6 Layers (Continued)

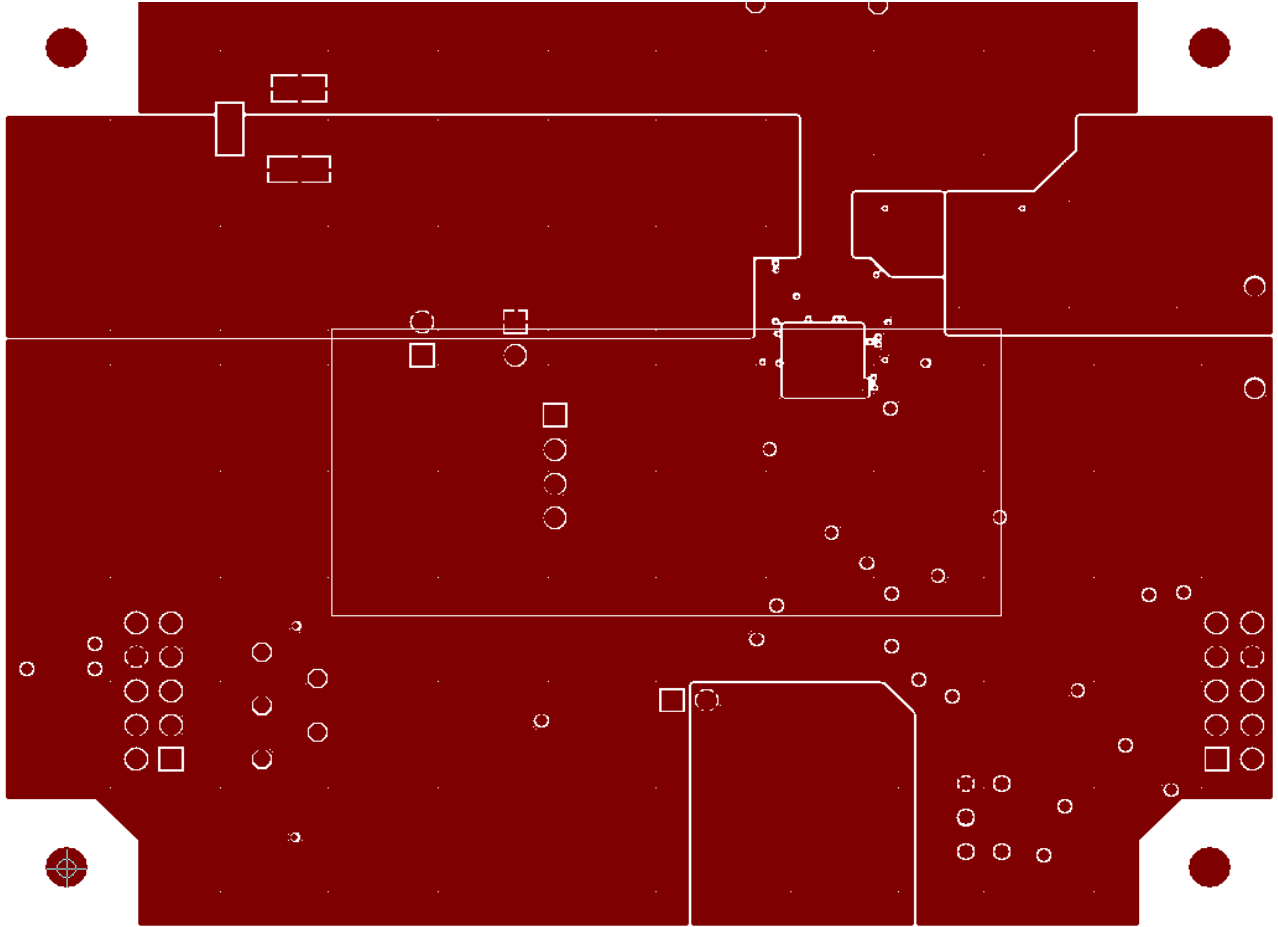

FIGURE 9. PCB - INNER LAYER 4 (VIEWED FROM TOP)

Board Layout – 6 Layers (Continued)

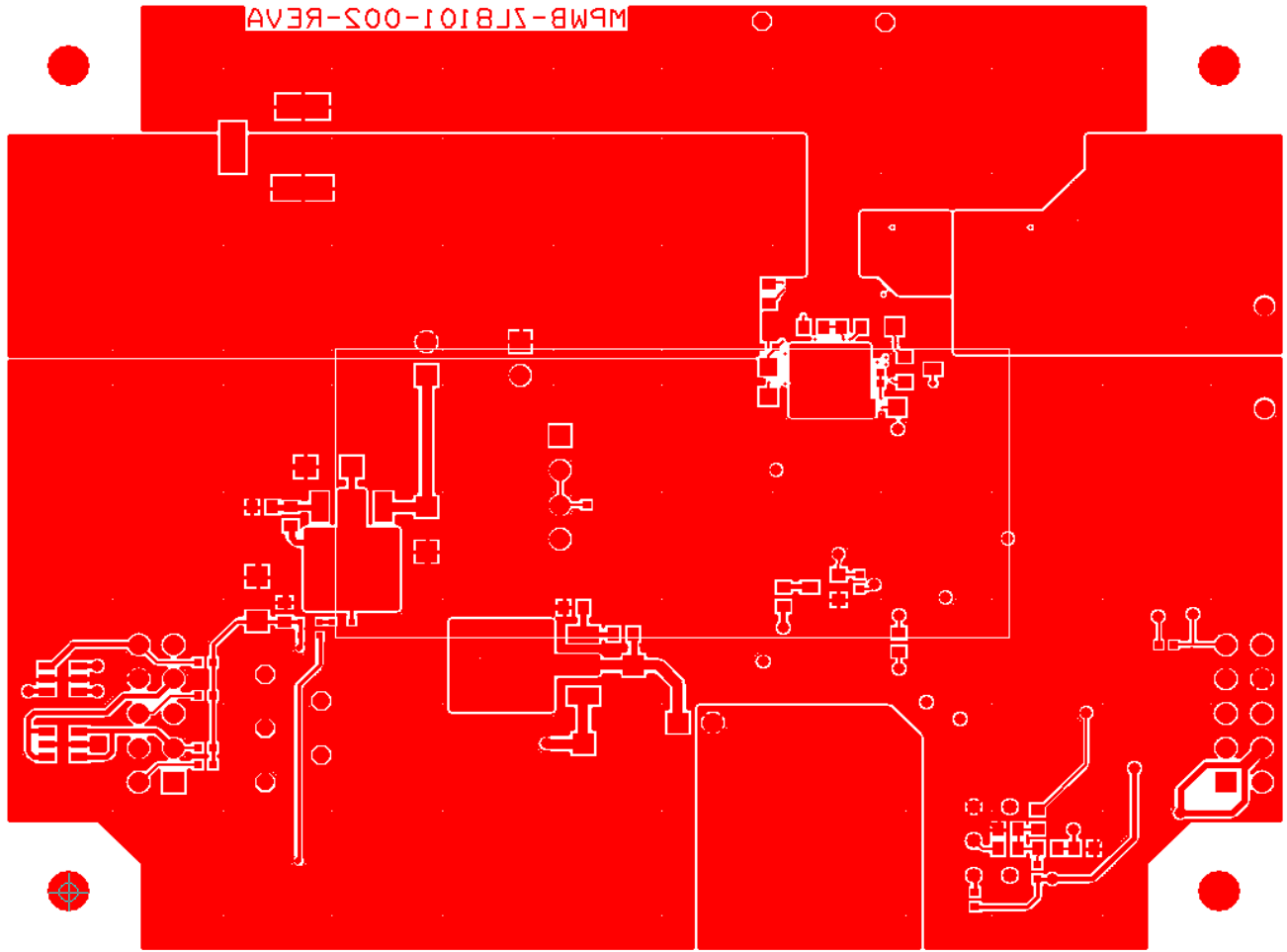

FIGURE 10. PCB - BOTTOM LAYER (VIEWED FROM TOP)

## Default Configuration Text

The following text is loaded into the ZL8101 device on the board as default settings. Each PMBus command is loaded via the PowerNavigator software. The # symbol is used for a comment line.

```
# Zilker Labs 8101 6/7/2012
# ZL Configuration File Revision A
# Schematic revision level
# BOM revision level
# Change log:
RESTORE_FACTORY
STORE_USER_ALL
STORE_DEFAULT_ALL
MFR_ID                Zilker_Labs
MFR_MODEL             30A
MFR_REVISION         REV_A
MFR_LOCATION         Austin
MFR_DATE             8/2012
MFR_SERIAL           1p0V_35A
VOUT_COMMAND         1.0
FREQUENCY_SWITCH     533
POWER_GOOD_DELAY     5
IOUT_SCALE           0.30
IOUT_CAL_OFFSET      -2.0
TON_DELAY            5
TON_RISE             5
TOFF_DELAY           5
TOFF_FALL            5
VOUT_OV_FAULT_RESPONSE 0x80
VOUT_UV_FAULT_RESPONSE 0x80
OVUV_CONFIG          0x80
IOUT_OC_FAULT_LIMIT  50
IOUT_AVG_OC_FAULT_LIMIT 45
IOUT_UC_FAULT_LIMIT  -40
IOUT_AVG_UC_FAULT_LIMIT -40
MFR_IOUT_OC_FAULT_RESPONSE 0x80
MFR_IOUT_UC_FAULT_RESPONSE 0x80
MFR_VMON_OV_FAULT_LIMIT 7.0
VMON_OV_FAULT_RESPONSE 0x80
MFR_VMON_UV_FAULT_LIMIT 4.5
VMON_UV_FAULT_RESPONSE 0x80
VIN_OV_WARN_LIMIT    14.3
VIN_OV_FAULT_LIMIT   14.5
VIN_OV_FAULT_RESPONSE 0x80
VIN_UV_WARN_LIMIT    4.2
VIN_UV_FAULT_LIMIT   4.0
VIN_UV_FAULT_RESPONSE 0x80
OT_WARN_LIMIT        110.0
OT_FAULT_LIMIT       125
OT_FAULT_RESPONSE    0x80
UT_WARN_LIMIT        -20
UT_FAULT_LIMIT       -40
```

## Application Note 1781

---

UT_FAULT_RESPONSE	0x00
DEADTIME	0x0C0C
DEADTIME_CONFIG	0x8686
DEADTIME_MAX	0x0C0C
MAX_DUTY	94
TRACK_CONFIG	0x00
INTERLEAVE	0x0000
#SEQUENCE	0x0000
MFR_CONFIG	0x6A10
NLR_CONFIG	0x00000000
TEMPCO_CONFIG	0x28
MISC_CONFIG	0x2000
ISHARE_CONFIG	0x0000
AUTO_COMP_CONFIG	0x79
PID_TAPS	A=6504.62, B=-11568.50, C=5078.00
USER_CONFIG	0x0011
DDC_GROUP	0x00000000
#DDC_CONFIG	0x0000
INDUCTOR	0.22
ON_OFF_CONFIG	0x1A
STORE_DEFAULT_ALL	
RESTORE_DEFAULT_ALL	

# Application Note 1781

## Measured Data

The following data was acquired using a ZL8101\_30AEV2Z 30A Demo Board.

### EFFICIENCY

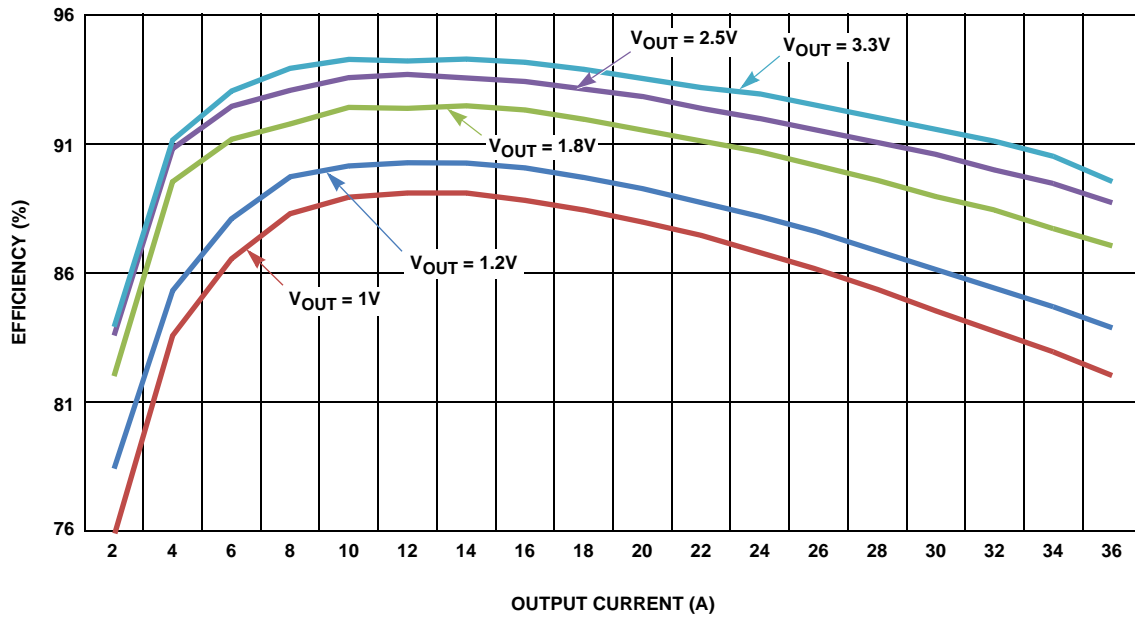

FIGURE 11. EFFICIENCY FOR DIFFERENT OUTPUT VOLTAGES,  $V_{IN} = 12V$ ,  $F_{SW} = 533kHz$

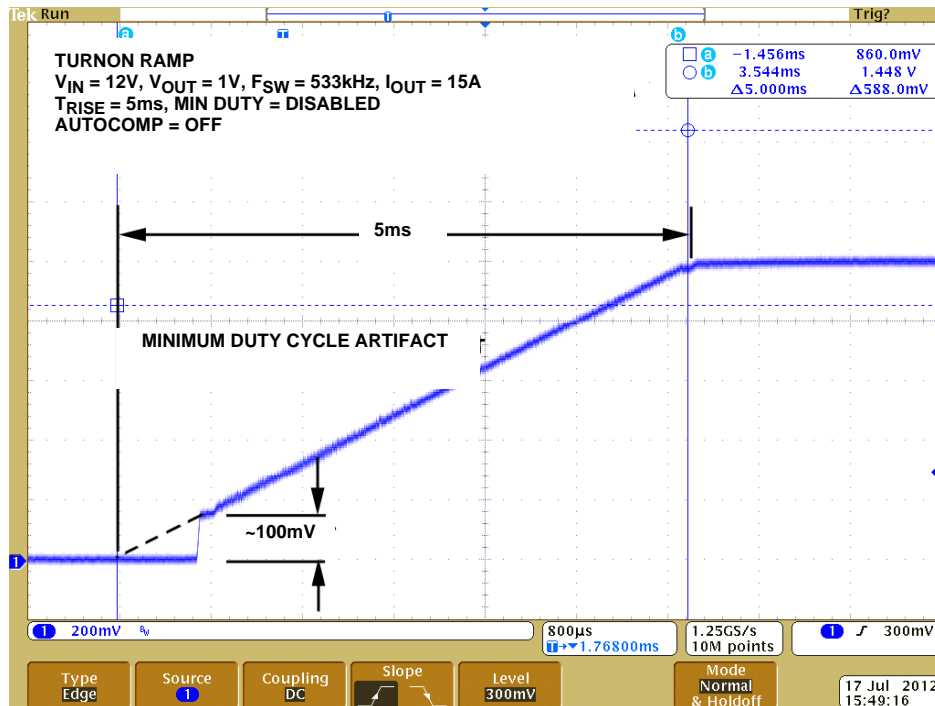

FIGURE 12. RAMP UP



# Application Note 1781

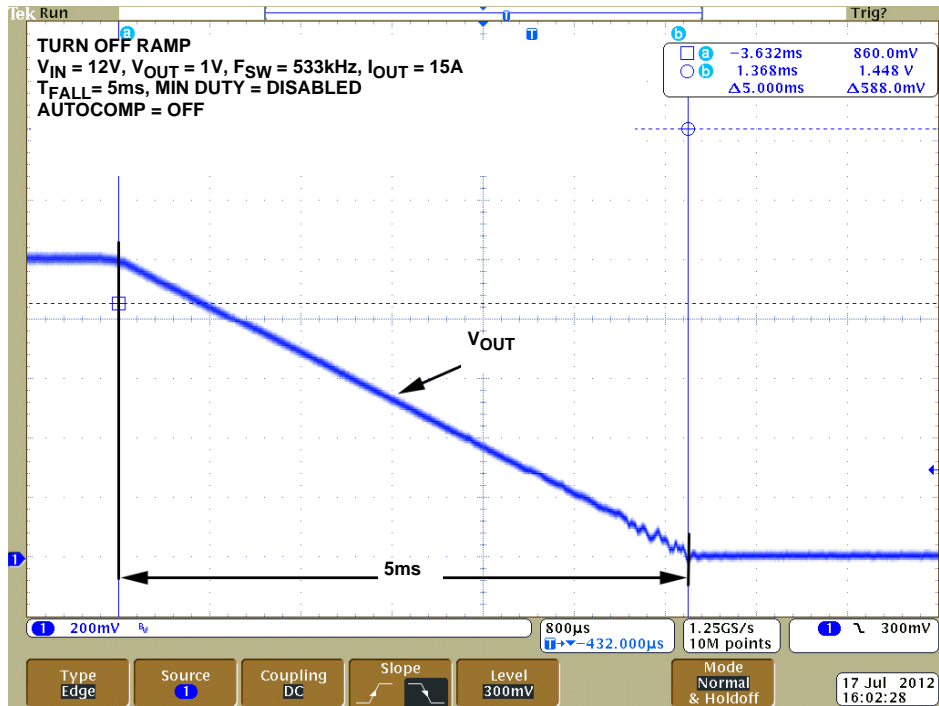

FIGURE 13. RAMP DOWN

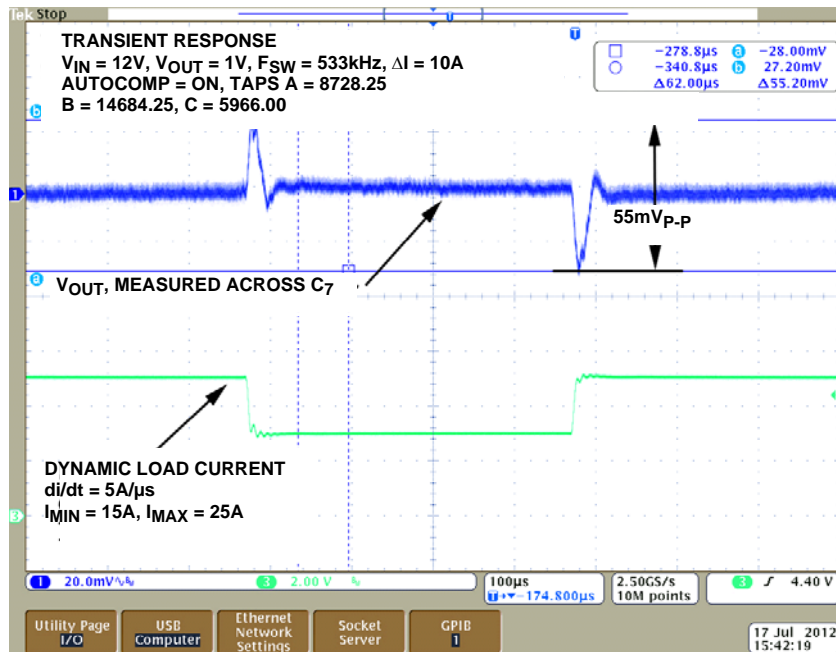

FIGURE 14. DYNAMIC RESPONSE, 10A TO 25A (AND VICE VERSA) LOAD STEP

# Application Note 1781

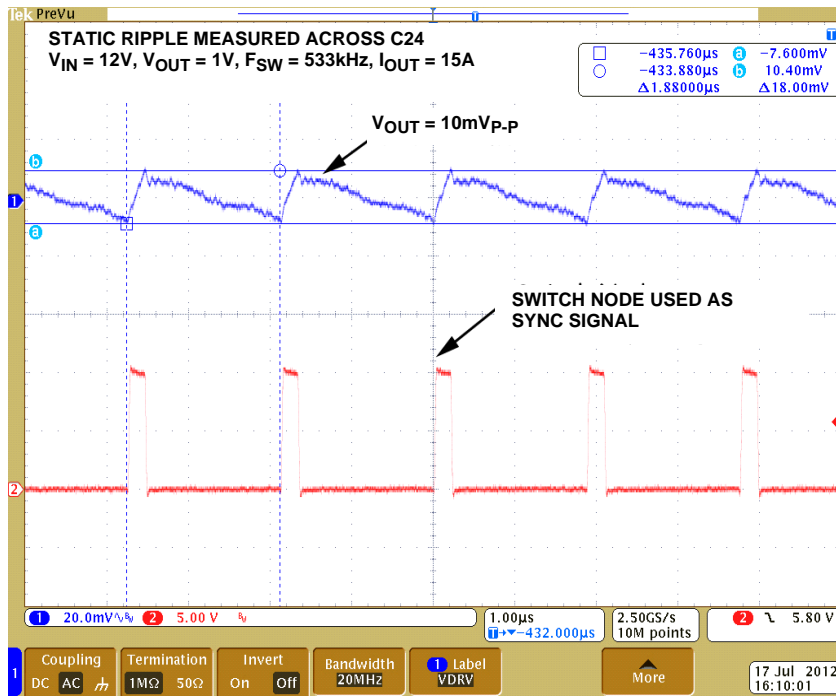

FIGURE 15. OUTPUT VOLTAGE RIPPLE WHEN  $V_O = 1V$ ,  $I_O = 25A$ ,  $V_{IN} = 12V$ ,  $F_{SW} = 800kHz$

## References

- [1] [ZL8101](#) Data Sheet, Zilker Labs, Inc., 2012.
- [2] [AN2033](#) – PMBus™ Command Set, Zilker Labs, Inc., 2009.

Intersil Corporation reserves the right to make changes in circuit design, software and/or specifications at any time without notice. Accordingly, the reader is cautioned to verify that the Application Note or Technical Brief is current before proceeding.

For information regarding Intersil Corporation and its products, see [www.intersil.com](http://www.intersil.com)